



Blackberry Wireless ePay
Installation and Configuration
guide

CONTENTS

SECTION 1	
Connecting the Blackberry to the PC	Page 04
SECTION 2	
Desktop Manager Installation	Page 05-06
SECTION 3	
Connection Settings (Desktop Manager)	Page 07
SECTION 4	
Installing Wireless ePay	Page 08-09
SECTION 5	
Activation Wireless & Bluetooth	Page 10-11
Activating Blackberry Wireless	Page 10
Activation Blackberry Bluetooth	Page 10
Bluetooth Pairing	Page 11
SECTION 6	
Activation Wireless ePay	Page 12
SECTION 7	
Printer Settings / Configuration	Page 13-14
SECTION 8	
Swiper Settings / Configuration	Page 15-16
SECTION 9	
Transaction Settings	Page 17
SECTION 10	
Merchant Settings	Page 18



If you are new to the BlackBerry mobile device, USAePay strongly recommends that you read the user guide provided with your BlackBerry and get more familiar with the use and functionality of your new hand held device.

Each BlackBerry includes a Desktop Manager installation CD and a USB cable. Both the CD and the USB cable will be required for the USAePay Wireless ePay installation. BlackBerry Desktop Manager software **MUST** be installed on to your computer before proceeding with Wireless ePay software installation.

(For Desktop Manager installation, please refer to the installation guide provided with the hand held device)

After the Wireless ePay installation is complete, the CD and the USB cable will not to be required for the Wireless ePay operation.

If using the W-ePaySC30 all in one Bluetooth device for swiping and printing, your mobile device will need to be configured (paired) to communicate with the W-ePaySC30. Refer to Section 5 of the BB Wireless ePay Installation Guide as well as the BlackBerry user guide.



SECTION 1

CONNECTING THE BLACKBERRY TO THE PC

To install Wireless ePay on to your Blackberry, the Blackberry must first be connected to your computer.

A USB cable is provided with your mobile device to allow the connection between the Blackberry and the PC.



fig. 1

The USB cable has two connectors, one at each end (fig. 1). The small connector (1) (fig. 2) is used for the Blackberry and the large connector (2) (fig. 2) is used for the PC.

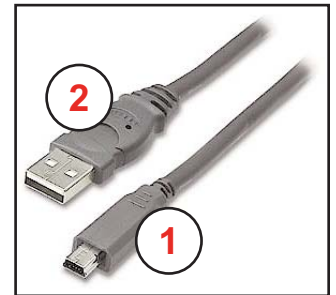

fig. 2

Step 1.

Turn the Blackberry unit ON.

Take the small USB connector (fig. 3) and plug it in into the USB port located on the right hand side of the Blackberry (fig. 4&5).



fig. 3



fig. 4



fig. 5

Step 2.

Take the large USB connector (fig. 6) and plug it in into the computer USB port (fig. 7&8).

NOTE: Location of USB port will vary.



fig. 6

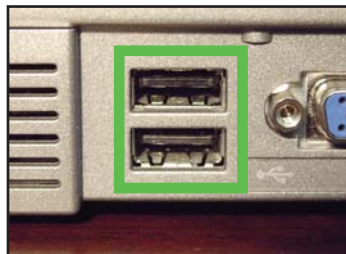

fig. 7



fig. 8

SECTION 2

DESKTOP MANAGER INSTALLATION

Section 2 will walk you through the installation of the Blackberry software on to your computer. Even though these steps are covered in section 2 of the desktop manager installation guide, USAePay highly recommends that you also read the Blackberry software installation guide provided to you along with the mobile device.

NOTE: The software names, versions and steps may vary depending on the purchased phone model. The screen images used are for demonstration purpose only.

Step 1.

Locate the Blackberry application setup file and double click it to begin setup.

Step 2.

Click the "Next"  button to continue with the setup (fig. 1).

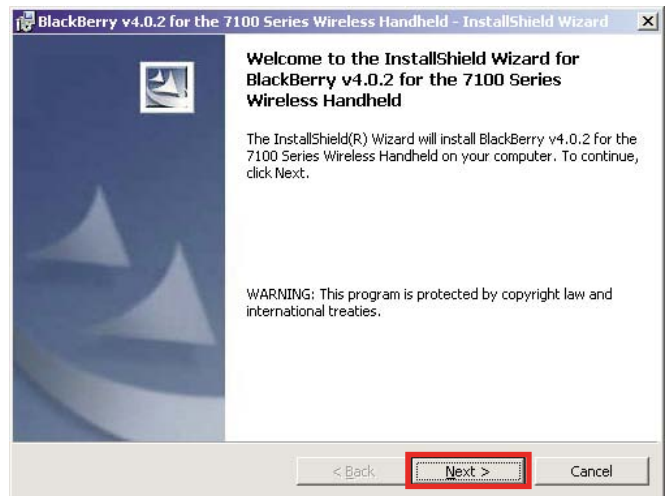



fig. 1

Step 3.

Select a language and press the "Next"  button to continue with the setup (fig. 2).

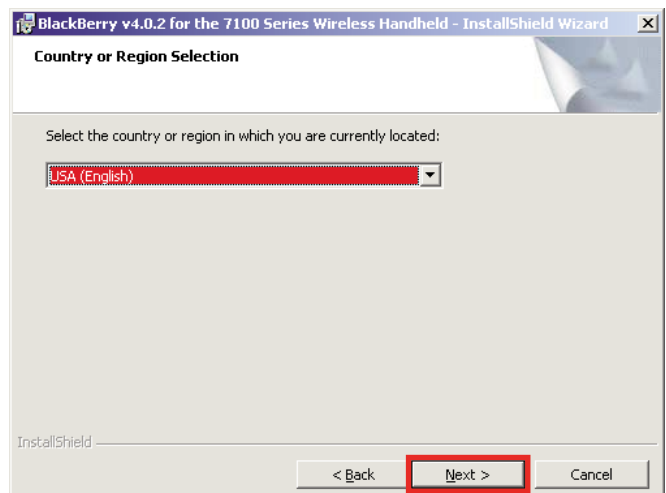



fig. 2

SECTION 2

DESKTOP MANAGER INSTALLATION - Cont.

Step 4.

Click "I accept the terms in the license agreement" and then click the "Next"  button to continue with the software installation (fig. 3).

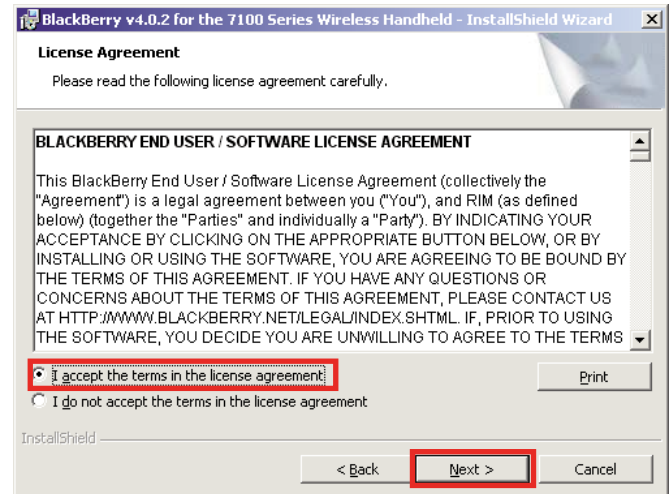



fig. 3

Step 5.

Check "Yes" I want to start the Desktop Manager Software" and click the "Finish"  button to complete the installation (fig. 4).

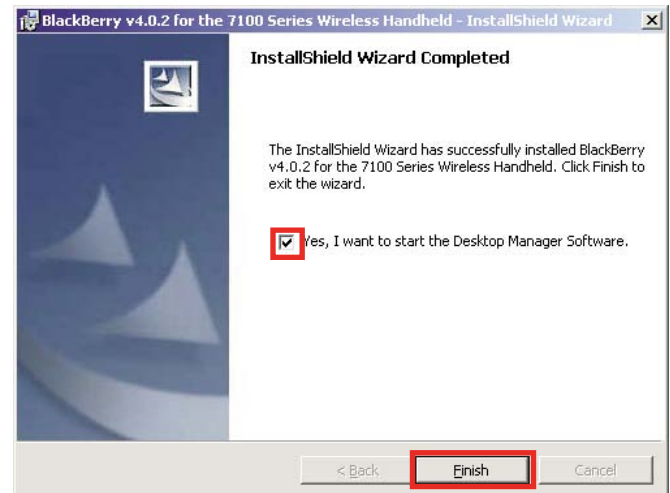

fig. 4

SECTION 3

CONNECTION SETTINGS

The Desktop Manager Software allows for applications to be installed on to a Blackberry.
NOTE: The Blackberry must be connected to the computer for software installation. Refer to section 1 for connection.

Step 1.

Start the Desktop Manager software.

Step 2.

Click on the "Options" menu then "Connection Settings". (Options -> Connections) (fig. 1)

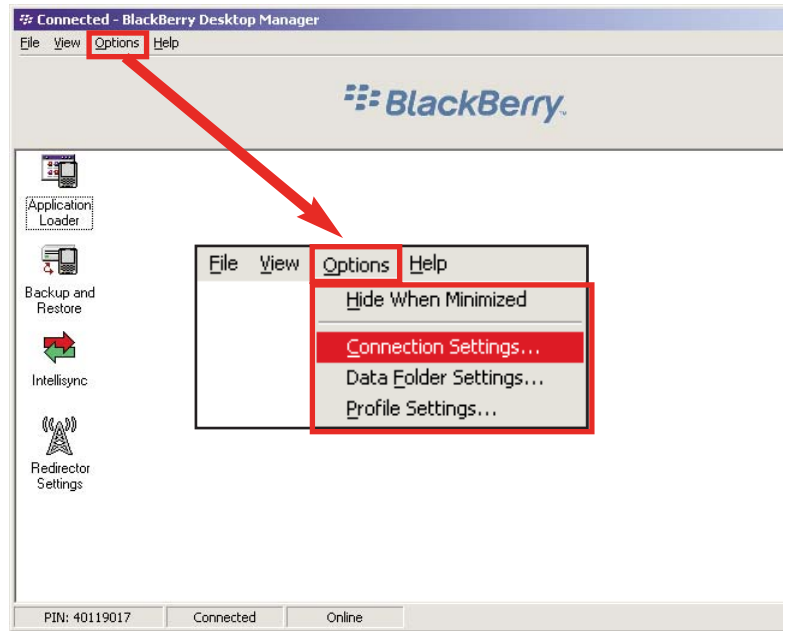

fig. 1

Step 3.

If not already selected, click on the "Connection:" drop down menu box and select the "USB" port, OR click the "Detect" button to auto detect connection type. Click the "OK" button to save the settings (fig. 2).

NOTE: The "Maximum Speed (bps):" should be set to "115200"

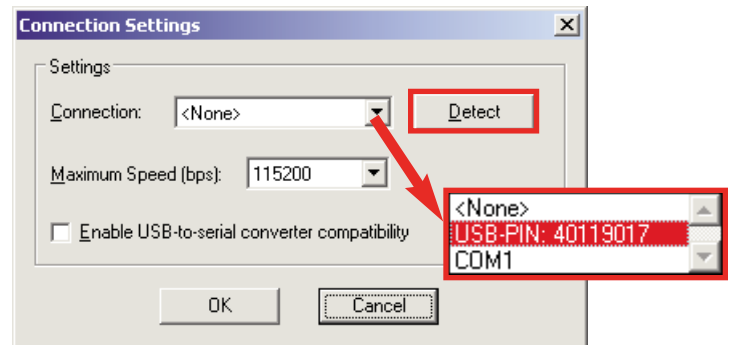



fig. 2

SECTION 4

INSTALLING WIRELESS EPAY

Step 1.

Start the "Application Loader". The Application Loader Wizard will begin. Click the "Next"  button to continue (fig. 1&2).

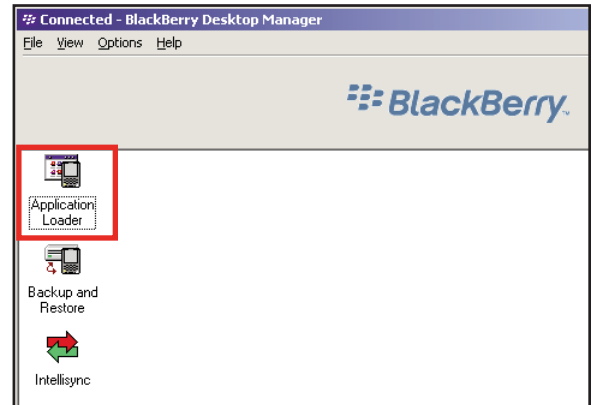

fig. 1

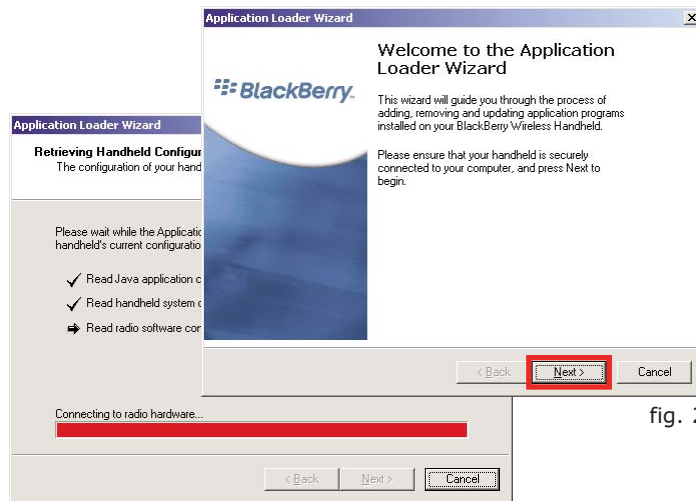
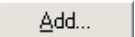

fig. 2

Step 2.

In the "Device Application Selection" box, click the "Add"  button (fig. 3).

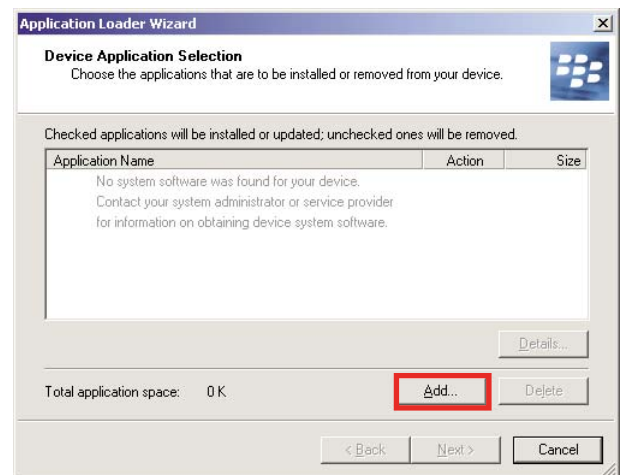
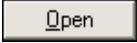

fig. 3

SECTION 4

INSTALLING WIRELESS EPAY - Cont.

Step 3.

The "Open" window will be displayed. At this point, you will locate the Wireless ePay file "ePayWireless.alx", select it and then click the "Open"  button (fig. 4).

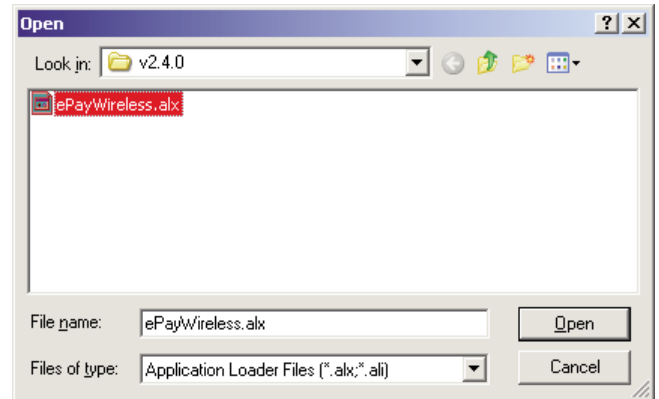



fig. 4

Step 4.

Make sure that the ePay Wireless is checked and click the "Next"  button to continue with the software installation. Click the "Finish"  button on the following screen (fig 5).

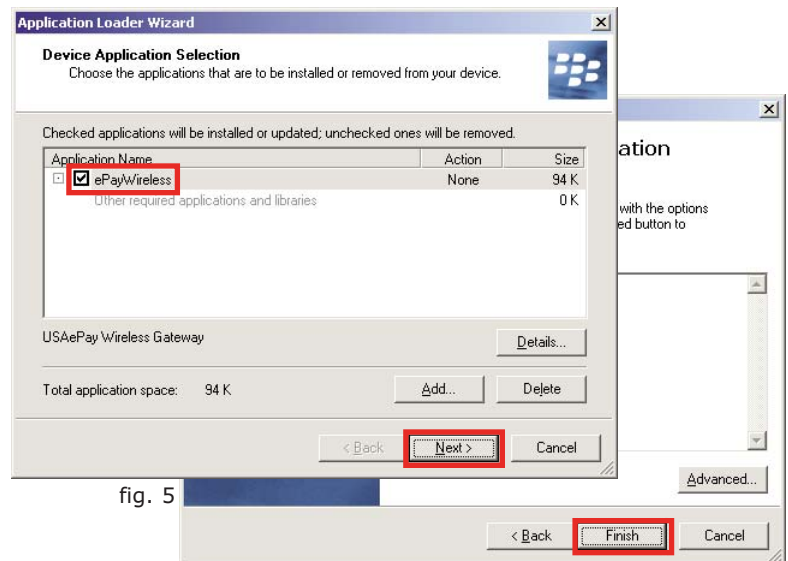
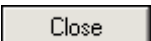

fig. 5

Step 5.

Once the installation is complete, click the "Close"  button (fig. 6).

The software has now been successfully installed on to the Blackberry. It is now safe to unplug the USB cable from the Blackberry.

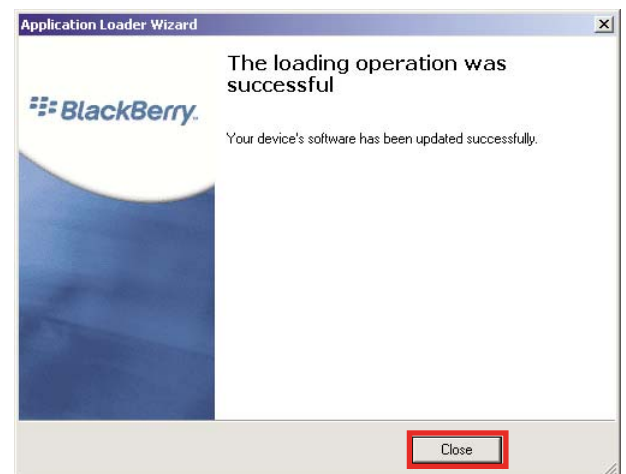

fig. 6

SECTION 5

ACTIVATING WIRELESS & BLUETOOTH

For the Blackberry to communicate the with W-ePaySC30 device, the Blackberry must first be paired with the swiper/printer device. By pairing the two devices together, this ensures that other bluetooth devices cannot communicate with the W-ePaySC30. Besides pairing the two devises together, the Blackberry wireless and Bluetooth features must also be activated.

Activating Blackberry Wireless

Step 1.

From the Blackberry main menu screen, scroll the thumbwheel till the Wireless icon is within the selection box (fig. 1).

Step 2.

Press the thumbwheel which will turn the wireless on and display the text "Turn Wireless Off" below the wireless icon. The wireless signal icon in the upper right corner will be activated and display wireless signal strength (fig. 1).

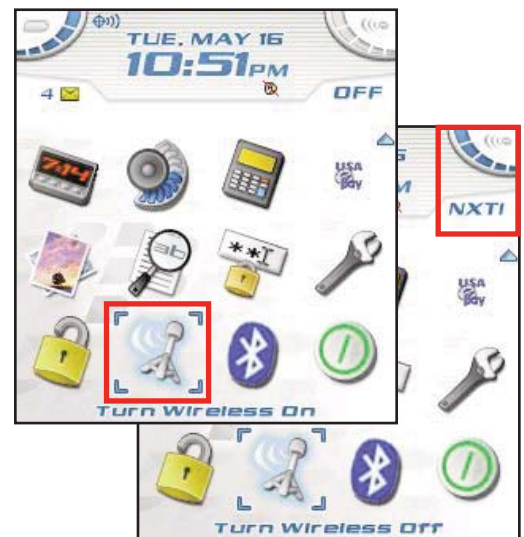

fig. 1

Activating Blackberry Bluetooth

Step 1.

From the Blackberry main menu screen, scroll the thumbwheel till the Bluetooth icon is within the selection box (fig. 2).

Step 2.

Press the thumbwheel which will turn the Bluetooth on (fig. 2).



fig. 2

SECTION 5

BLUETOOTH PAIRING

Step 1.

From the BlackBerry main menu screen, scroll the thumbwheel until the Options icon is within the selection box (fig. 1).



fig. 1

Step 2.

Press the thumbwheel to enter the Options Menu screen. In the Options menu, scroll the thumbwheel till the "Bluetooth" menu is selected (fig.2).



fig. 2

Step 3.

Press the thumbwheel to enter the "Paired Devices" menu. (fig.3)



fig. 3

Step 4.

Press the thumbwheel again and select the "Add Device". This will search for the W-ePaySC30 bluetooth unit. (fig.4)

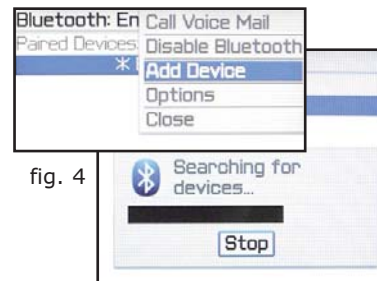

fig. 4

Step 5.

Once the W-ePaySC30 unit has been detected, scroll to select the "W-ePay" device and press the thumbwheel to select it. (fig. 5)



fig. 5

Step 6.

When the phone display asks for a passkey, enter **1793**. (fig. 6)

NOTE: If pairing fails, try again following from the beginning of step 3.

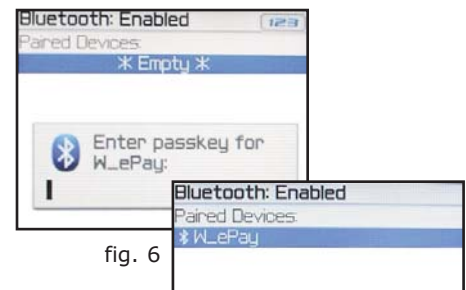

fig. 6

SECTION 6

ACTIVATING WIRELESS ePAY

Step 1.

From the Blackberry main menu screen, scroll the thumbwheel till the USAePay Wireless ePay icon is within the selection box. Press the thumbwheel to start the Wireless ePay application. (fig. 1)

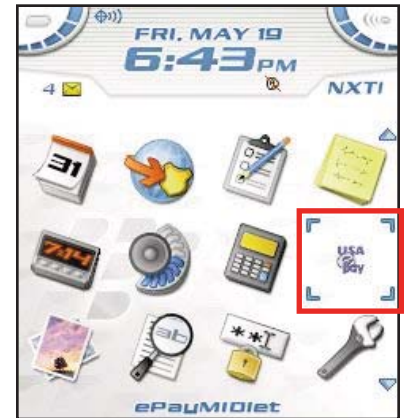

fig. 1

Step 2.

At this time you will be asked to enter two (2) pieces of information, "Create new PIN" and "Enter Install Key". (fig. 2)

The PIN must be 8 digits or more. (fig. 2)

NOTE: This PIN will be required every time the Wireless ePay application is run.



fig. 2

After the PIN has been entered, scroll the thumbwheel down. Enter the provided Install Key. (fig. 2)

NOTE: Once the Install Key has been activated it cannot be re-entered.

Step 3.

When the PIN and Install Key have been entered, press the thumbwheel and select "Install" (fig. 3).

After the activation has been approved, you will be asked to enter your PIN again.

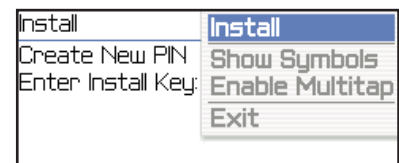

fig. 3

Enter the PIN and press the thumbwheel and select "Login" to log into Wireless ePay (fig. 4&5)

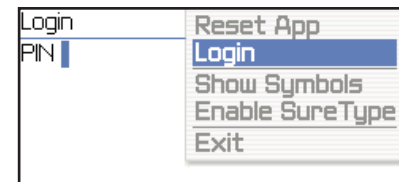

fig. 4



fig. 5

CONFIGURING WIRELESS ePAY

The W-ePaySC30 device must be configured with the Wireless ePay software before it can swipe or print out receipts. Section 7 will walk you through configuring the swiper and printer settings so credit card transaction can take place through the Wireless ePay software.

Using the thumbwheel, scroll down and select the "Settings" options. Press the thumbwheel and select "Select" from the menu. (fig. 1)

NOTE: Two "Select" choices will be available, either one will work.

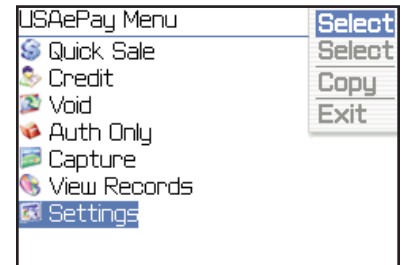

fig. 1

SECTION 7

PRINTER SETTINGS/CONFIGURATION

Step 1.

Within the settings screen, scroll down to the "Printer Settings", press the thumbwheel and choose "Select" to enter the printer settings. (fig. 1)

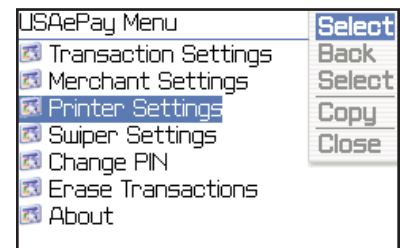

fig. 1

Step 2.

Within the "Printer Settings", the default setting is "None". (fig. 2)

Using the thumbwheel, scroll down to select the "Bluetooth Printer".

Press the thumbwheel and choose the "Select" option. (fig. 3)

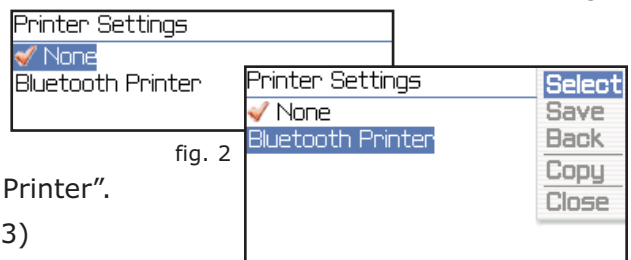

fig. 2

fig. 3

Step 3.

When the "Bluetooth Device Settings" message appears, press the thumbwheel and select "Search". This will search for the W-ePaySC30 device. (fig. 2)

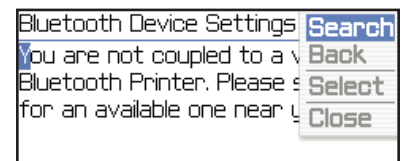

fig. 4

SECTION 7

PRINTER SETTINGS/CONFIGURATION - Cont.

Step 4.

Two options will be displayed. "None" and "BT Serial" (fig. 5). Scroll down to select "BT SERIAL", press the thumbwheel and select "Change Options" (fig. 6). You will now see that the "BT SERIAL" is selected with a bullet point (fig. 7).

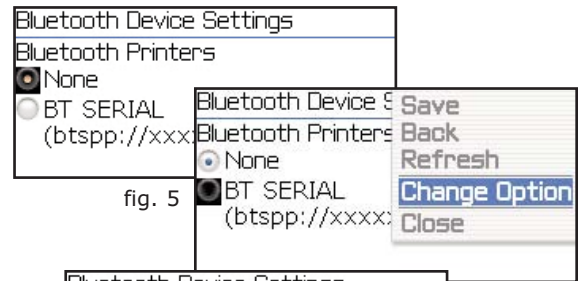

fig. 5

fig. 6

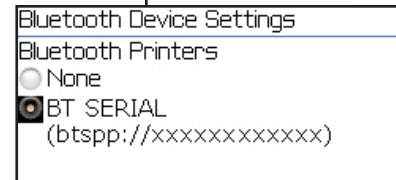

fig. 7

Step 5.

With the "BT SERIAL" selected, press the thumbwheel, and choose "Save" (fig. 8). In the "Printer Settings" windows, click the thumbwheel and "Save" again (fig. 9). Once saved, a single confirmation tone and "The settings have been saved" confirmation window will be displayed (fig. 10).

NOTE: If "The settings have been saved" confirmation was not displayed, then the settings have not been saved and the W-ePaySC30 device will not properly function.

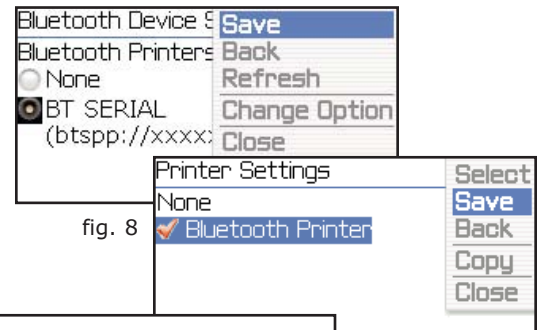

fig. 8

fig. 9

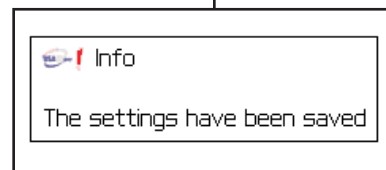

fig. 10

SECTION 8

SWIPER SETTINGS/CONFIGURATION

Step 1.

Within the settings screen, scroll down to the "Swiper Settings", press the thumbwheel and choose "Select" to enter the swiper settings. (fig. 1)

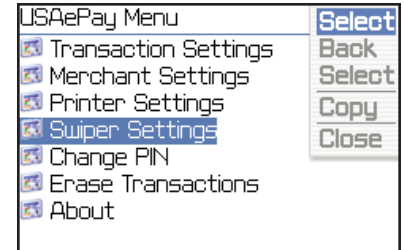

fig. 1

Step 2.

Within the "Swiper Settings", the default setting is "None". (fig. 2)

Using the thumbwheel, scroll down to select the "Bluetooth Swiper".

Press the thumbwheel and choose the "Select" option. (fig. 3)

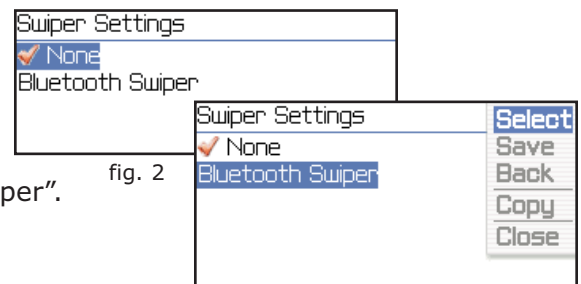

fig. 2

fig. 3

Step 3.

When the "Bluetooth Device Settings" message appears, press the thumbwheel and select "Search". This will search for the W-ePaySC30 device. (fig. 4)

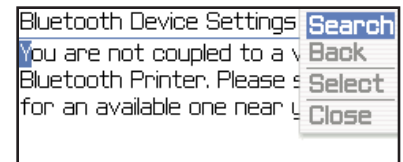

fig. 4

Step 4.

Two options will be displayed. "None" and "BT Serial" (fig. 5). Scroll down to select "BT SERIAL", press the thumbwheel and select "Change Options" (fig. 6). You will now see that the "BT SERIAL" is selected with a bullet point (fig. 7).

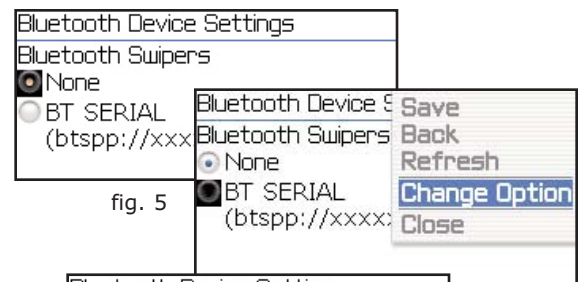

fig. 5

fig. 6

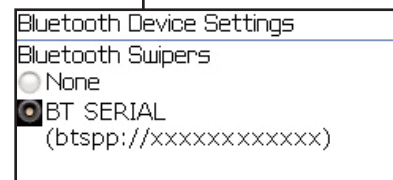

fig. 7

SECTION 8

SWIPER SETTINGS/CONFIGURATION - Cont.

Step 5.

With the "BT SERIAL" selected, press the thumbwheel, and then choose "Save" (fig. 8). The "W-ePay SC30" will now be displayed as a selection within the "Swiper Type" window. Press the thumbwheel and then choose "Select" (fig. 9). A checkmark will be placed to the left of the "W-ePay SC30" in the "Swiper Type" window. Press the thumbwheel and then choose "Save" (fig. 10). This time a checkmark will be placed to the left of the "Bluetooth Swiper" in the "Swiper Settings" window. Press the thumbwheel again and then choose "Save" (fig. 12).

Once saved, a single confirmation tone and "The settings have been saved" confirmation window will be displayed (fig. 12).

NOTE: If "The settings have been saved" confirmation was not displayed, then the settings have not been saved and the W-ePaySC30 device will not properly function.

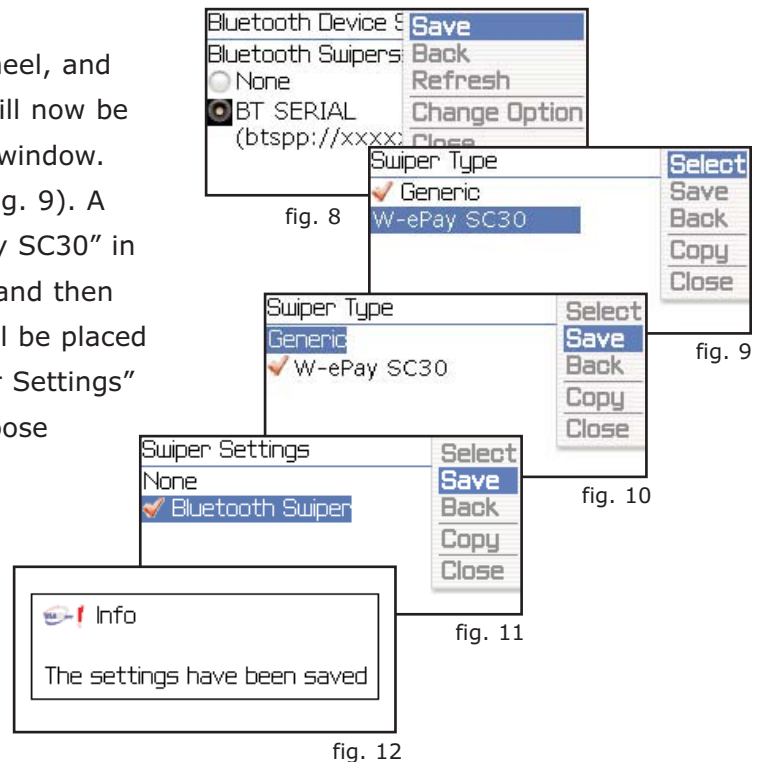

SECTION 9

TRANSACTION SETTINGS

Step 1.

Use the thumbwheel to select "Transaction Settings". Click the thumbwheel and select choose "Select". (fig. 1)

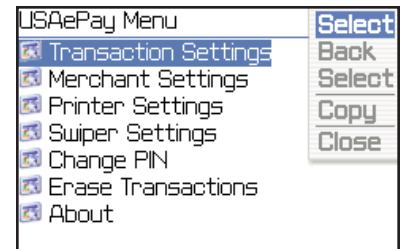

fig. 1

Days Records Stored:

This is how many days records will be stored within Wireless ePay software. (fig. 2)

NOTE: By increasing the days stored, you are depleting your cell phone of memory. Default is 90 days.

Tax:

By entering a tax value in to the "Transaction Settings", the tax field in the "Sale" & "Credit" menus will be automatically populated. (fig. 2)

Default is 0.

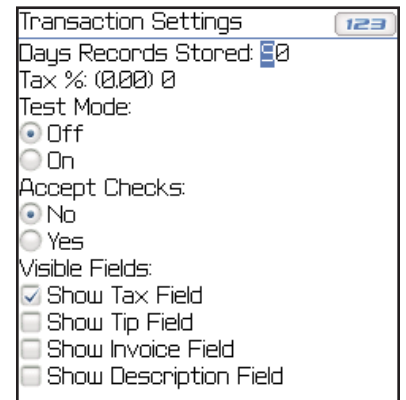

fig. 2

Test Mode:

This option sets Wireless ePay into a test mode. When in test mode, Wireless ePay is fully functional except that the transactions do not get processed. (fig. 2) *Default is Off.*

Accept Checks:

If enabled, this feature allows one to process eChecks directly through Wireless ePay. (fig. 2)

NOTE: Default is No.

Visible Fields:

If enabled, these fields will show in the Sale and Credit menus. If not using any of these features for transaction, simply uncheck the field and it will not be displayed within the menu. (fig. 2)

Step 2.

To save the settings, click the thumbwheel, scroll to "Save" and click the thumbwheel again. (fig. 3)

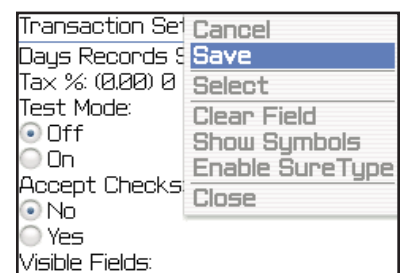

fig. 3

SECTION 10

MERCHANT SETTINGS

Step 1.

Use the thumbwheel to select "Merchant Settings". Click the thumbwheel and choose "Select". (fig. 1)

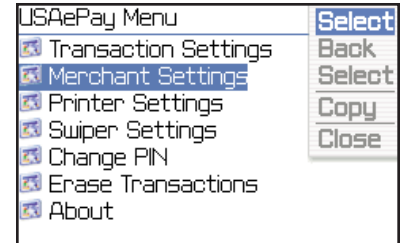

fig. 1

Step 2.

Fill in all the necessary company contact info. This info will be printed as a header for each successful transaction. (fig. 2)

NOTE: Leave blank if you do not wish to print company info on receipt.

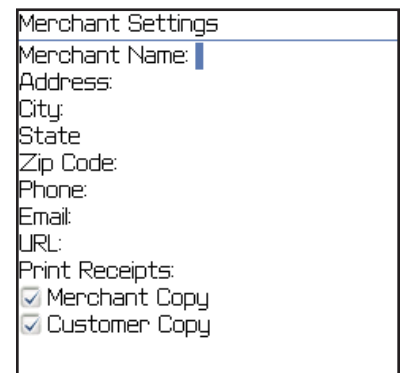

fig. 2

Step 3.

Once the info is entered, use the thumbwheel to "Save" the settings. (fig. 3)

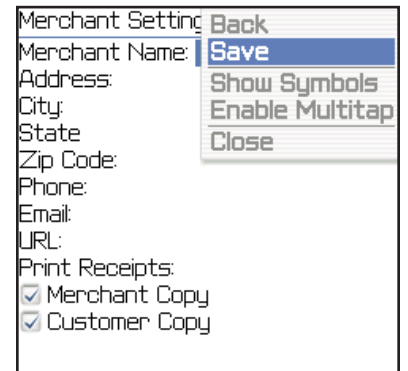

fig. 3